

1100

Spruce Street

Boulder, CO

710 SF OF RETAIL SPACE FOR LEASE
1,023 SF OF OFFICE SPACE FOR LEASE

AS A PUBLICLY-CONTROLLED PROPERTY, the owner is seeking tenants that will contribute to a vibrant, diverse, and inclusive retail district

AFFORDABLE COMMERCIAL OPPORTUNITY FOR ELIGIBLE BUSINESSES



Property Highlights



CORNER OF
SPRUCE & 11TH



1 BLOCK FROM
PEARL STREET



EXCELLENT
VISIBILITY



RETAIL
SPACE
AVAILABLE

Available Suites

Suite 201

1,023 SF
OF SECOND
FLOOR OFFICE
SPACE



Suite 104

710 SF
OF FIRST
FLOOR RETAIL
SPACE



Floor Plans

Suite 104

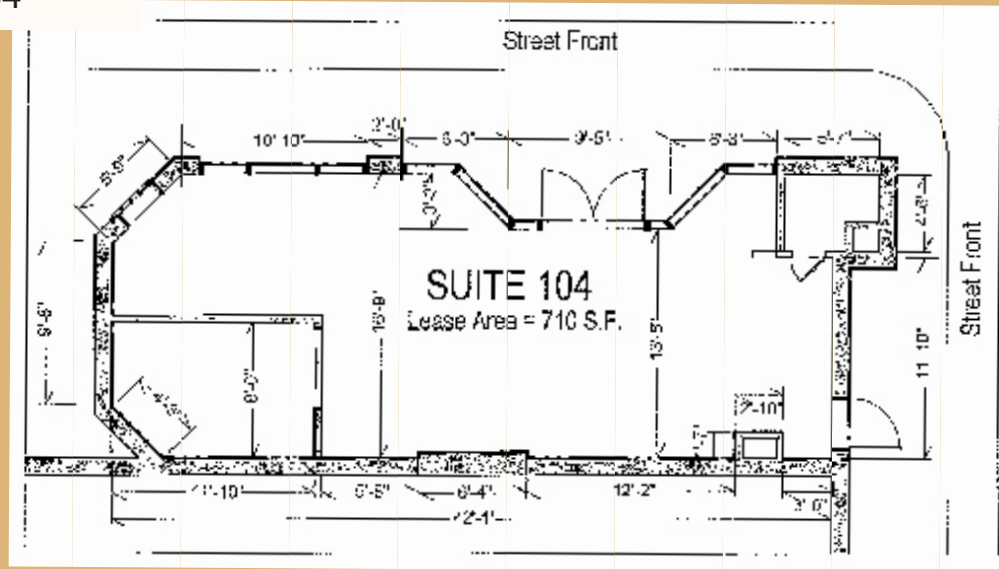

Suite 201

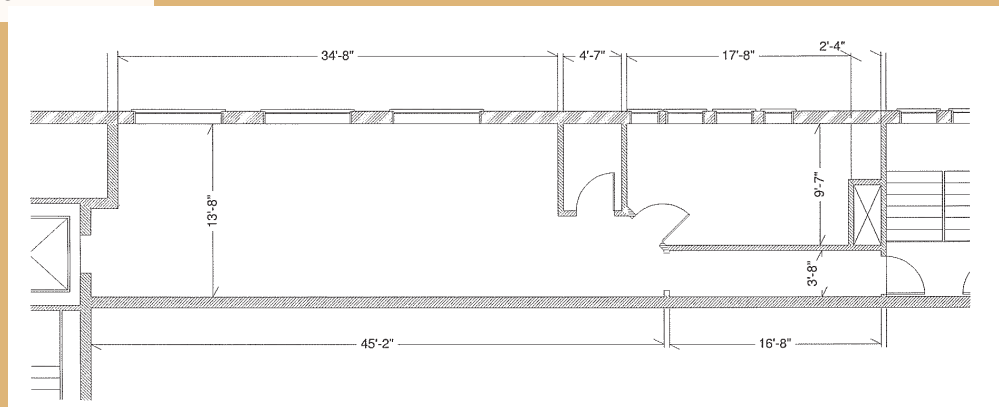

Location Highlights

Boulder, Colorado

Just 30 miles from Denver, Boulder is a beautiful, historic city surrounded by the gorgeous Flatiron Mountains and just moments away from Boulder Creek. Boulder is brimming with wonderful shopping, dining, and entertainment opportunities — there is truly something for everyone. Downtown Boulder is well-kept, with over 1000 businesses and a welcoming atmosphere. The Pearl Street Walkway, a marvelously captivating four-block-long pedestrian mall in the heart of Downtown Boulder, is filled with colorful, vibrant flowers virtually the entire year. Downtown Boulder is a vibrant and exciting place for locals and visitors alike.



POPULATION

2020 Population - Current Year Estimate

1 MIILE

24,772

3 MILES

91,906

5 MILES

116,224



HOUSEHOLD INCOME

2020 Average Household Income

\$98,308

\$108,444

\$115,931



PLACE OF WORK

2020 Employees

31,813

90,357

105,862





Spruce Street

Boulder, CO



MOLLY BAYER | Senior Associate

+1 303 264 1925

molly.bayer@cbre.com



© 2023 CBRE, Inc. All rights reserved. This information has been obtained from sources believed reliable, but has not been verified for accuracy or completeness. You should conduct a careful, independent investigation of the property and verify all information. Any reliance on this information is solely at your own risk. CBRE and the CBRE logo are service marks of CBRE, Inc. All other marks displayed on this document are the property of their respective owners, and the use of such logos does not imply any affiliation with or endorsement of CBRE. Photos herein are the property of their respective owners. Use of these images without the express written consent of the owner is prohibited.PMStudio_June2023